

A Novel Design of Single Switch Long Life LED Driver

Sreeram K¹ and Mr. Unnikrishnan L²

¹PG Scholar, Dept. of Electrical and Electronics Engineering, Rajagiri School of Engineering and Technology, Rajagiri Valley P.O, Kochi-682039, Kerala, India
Email:sreeramk65@gmail.com

²Asst.Professor, Dept. of Electrical and Electronics Engineering, Rajagiri School of Engineering and Technology, Rajagiri Valley P.O, Kochi-682039, Kerala, India
Email:unnikrishnan4u@gmail.com

Abstract—Energy-efficient residential lighting such as household light-emitting diode (LED) lamps with AC input require electrolytic capacitor as the energy storage dc-link capacitor in the driver circuit to balance the energy between the input and output power and reduce the low frequency LED current ripple. The average lifetime of an electrolytic capacitor is at least 2–3 times less than that of an LED lamp which affects the potential lifetime of the overall circuit. To increase the lifetime of the LED lighting system, an offline LED driver that does not use any electrolytic capacitors or complicated control circuits to minimize the low-frequency (i.e., 100 or 120 Hz) output ripple is presented here. The proposed single switch circuit reduces the energy storage capacitance to a few microfarads range, so that film capacitor can be used to replace the unreliable electrolytic capacitor. The circuit operating principles and its theoretical analysis are studied and simulation results are given on a 9-W LED lamp to highlight the merits of the proposed circuit.

Index Terms— Current Ripple; Efficiency; Electrolytic Capacitor; Light-Emitting Diode (LED); Power Factor.

I. INTRODUCTION

Lighting accounts for over 20% of the overall worldwide energy consumption. To reduce the energy cost consumed by lighting, light emitting diode (LED) lamps are used as they are eco friendly, durable, mercury-free and have much higher energy efficacy and longer lifetime than other lighting technologies. The global market model predicts that LED market share in the residential segment will increase to almost 50% in 2017 and over 70% by 2020 [1]. LEDs are thermally sensitive devices whose functioning is determined by the driving current in the LEDs. A current limiting device is therefore, required to ensure proper LEDs operation to keep the peak current below the rated current. In residential or commercial lighting with AC input line frequency of 50Hz, the harmonics of the AC input current drawn from lighting equipments such as the LED lamps should meet the IEC 61000–3–2 Class C standards [2]. Moreover, the Energy Star Criteria for Solid State Lighting Luminaries specifies that the input power factor of the LED lamp in commercial and residential lighting applications must be greater than 0.9 and 0.7 respectively [3]. Active power factor corrected LED driver circuit [3] can be a single-stage switch-mode DC/DC converter

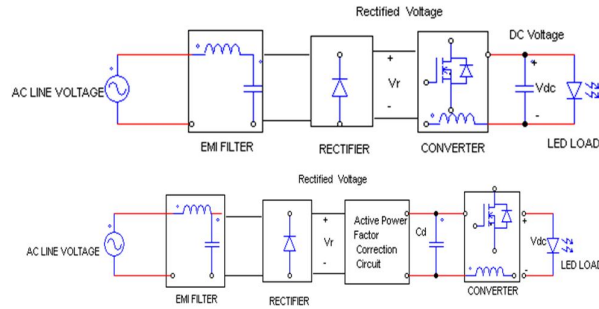

Fig.1. Typical AC/DC single stage and two-stage LED driver

(i.e., buck or flyback with Discontinuous Conduction Mode (DCM) for Power Factor Correction (PFC) or a two-stage converter that consists of a front-end boost converter [4] for PFC as shown in Fig. 1. The two-stage approach allows smaller energy storage capacitance (C_d) due to the large input impedance of the second stage DC/DC converter, but the number of electronic components, size and cost of the driver circuit increases leading to lower efficiency. With sinusoidal AC input current I_{AC} , large output capacitance is used at the output of the LED driver circuit to compensate the energy difference between the pulsating input power and the output DC power delivered to the LED load. Large variation in the low-frequency ripple of the LED current causes visible flickering irritating human vision [5].

II. PROBLEM IDENTIFICATION AND SOLUTION

As mentioned above, to minimize the LED driver size and overall cost, electrolytic capacitor is the most cost-effective energy storage component choice due to its high energy density. Average lifetime of electrolytic capacitor is only 10000 hours compared with the lifetime of an LED semiconductor device, which lasts 100000 hours thus reducing the lifetime of overall LED system [6]. Electrolytic capacitors are unreliable owing to their sensitivity to their operating temperature, ripple current, and internal equivalent series resistance, low electromagnetic immunity, low overvoltage capabilities. As a literature survey, different AC/DC driver solutions on eliminating the electrolytic capacitors for LED lighting was studied. In [7], flyback converter with a bidirectional buck-boost converter at the flyback's output was used to absorb the pulsating component of the LED current to eliminate low frequency component of the LED current and the output energy storage capacitor used in the conventional flyback converter. In [8], a modified flyback converter with an additional auxiliary winding and three switches was presented to provide almost constant current to the output. In [9], a coupled inductor PFC single-switch LED driver circuit is proposed but the switch suffers very high current and voltage stress as the switch needs to handle both PFC inductor current and LED current resulting in low efficiency. In [10], an isolated single-switch AC/DC electrolytic capacitor-less LED driver was proposed but the three winding transformer increases the cost and size. In [11], a electrolytic capacitor-less LED driver based on two cascaded flyback converters was proposed but it doesn't have the dimming feature for current control.

Past LED driver circuits need complex power circuits (multiple switches or multiple stages), current control techniques to reduce the size of the energy storage capacitor or using large size high voltage film capacitors. This paper proposes a simple, reliable electrolytic capacitor-less long life LED driver. It is a single-stage single-switch topology and provides high frequency pulsating output current without any feedback control circuit to regulate the low-frequency ripple in the LED current.

III. PROPOSED LED DRIVER CIRCUIT

The energy storage component is moved from output to the intermediate stage of the converter to reduce the energy storage capacitance. Two DCM flyback converters are cascaded in series. Suppose switches M_1 and M_2 has the same switching frequency, duty cycle and same turns ratio for L_{m1} and L_{m2} , then $i_{L_{m1}}$ and $i_{L_{m2}}$ both rise linearly when the switches are on and i_{D1} and i_{D2} both discharge the current when the switches are OFF. Magnetic coupling can be formed between the secondary winding of L_{m1} and the primary winding of L_{m2} . When a load is connected in series with the primary winding of L_{m2} and a voltage source is connected

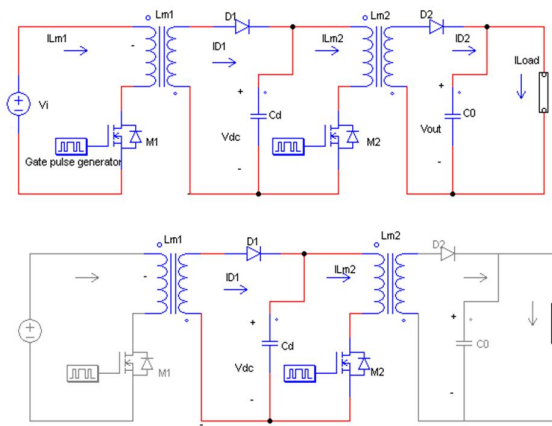

Fig. 2. Derivation of proposed circuit from cascaded flyback converters

in series with the secondary winding of L_{m1} , then the load will be driven by a high frequency pulsating triangular waveform. The resulting LED driver consists of a MOSFET (M), a fast-recovery diode (D), an energy storage capacitor (C_d), a high frequency filtering capacitor (C_l), and a two-winding (N_p and N_s) coupled inductor with inductance (L_m), where L_m is the inductance referred to the primary side. Input current flows through the diode instead of the switch. Coupled inductor L_m feeds back part of the required energy to the dc-link capacitor (C_d) within the line cycle to reduce the capacitance needed to minimize the output ripple. Thus, the conventionally used electrolytic capacitor can be replaced by a film capacitor with reasonable size. Series connected L_m and the switch (M) provide a high frequency pulsating current waveform at the output to the LED.

A. Circuit Operating Principles

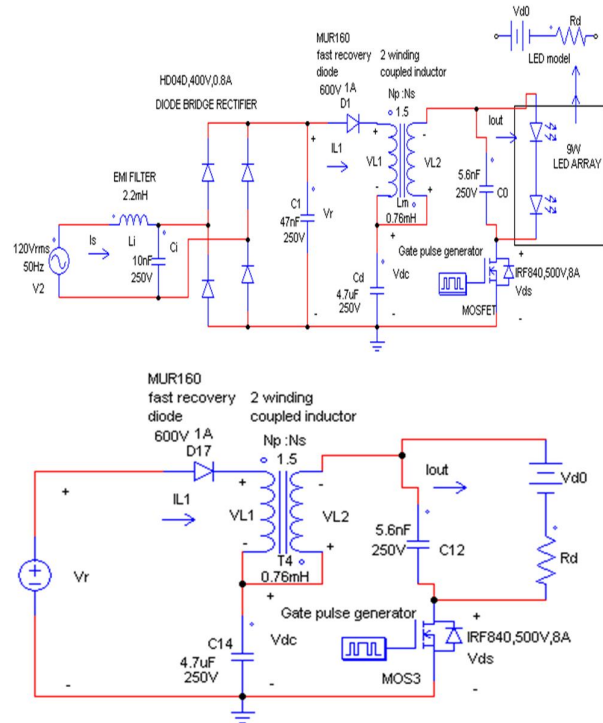

Fig. 3. Proposed pulsating current LED and Equivalent circuit with rectified voltage source

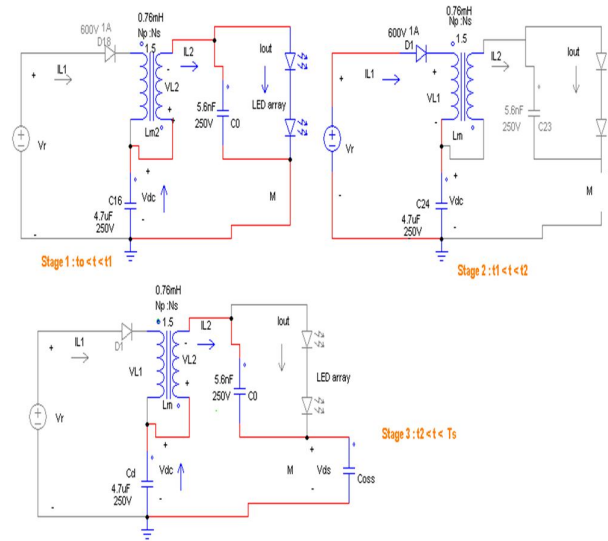

Fig. 4. Operating stages of the proposed LED driver

[Stage 1: $t_0 < t < t_1$]: When the gate pulse (V_G) goes high and MOSFET turns ON, the current (i_{out}) flowing through the LEDs increases and is given by the current flowing through the secondary winding (L_{sec}) of the coupled inductor and LED bulb glows .

[Stage 2: $t_1 < t < t_2$]: When the gate pulse (V_G) goes low ,MOSFET turns OFF and the MOSFET voltage (V_{ds}) rises and i_{out} drops to zero. Due to reverse polarities between the two windings of L_m , D_1 turns ON and the stored energy in L_{sec} is now transferred to C_d through the primary side of L_m .As V_{dc} is greater than V_r , V_{L1} becomes negative and hence, i_{L1} decreases linearly (Δt_1 is the discharging period of L_m current). Power Factor Correction (PFC) at input side is achieved by operating L_m , the magnetizing inductance of the transformer in Discontinuous Conduction Mode (DCM).

Voltage across C_d is boosted from V_r and average rectified current is equal to the average current flowing through D_1 By operating the power factor corrector in DCM, the current flowing through D_1 follows the low frequency voltage envelope provided by the difference between v_r and v_{dc} .

[Stage 3: $t_2 < t < T_s$]: As MOSFET and D_1 are OFF, V_{dc} remains at the same level. The presence of C_o provides a current path between L_m and output capacitance (C_{oss}) of the switch when the switch is OFF.High frequency oscillation occur in V_{L1} and V_{ds} due to resonance between L_m and C_{oss} . C_o should be very small so that it is sufficient to minimize the output high frequency voltage ripple and does not impose significant oscillation on V_{ds} .

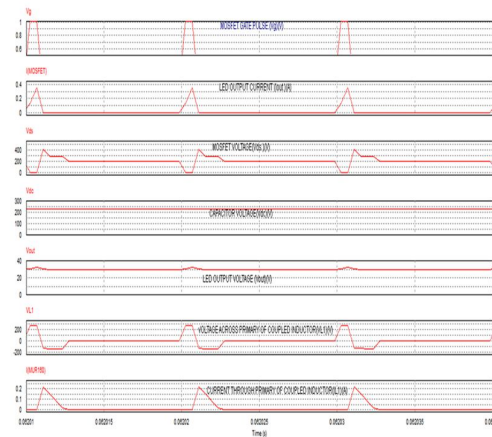

Fig. 5. Key Waveforms of the Proposed pulsating current LED driver

III. DESIGN OF THE DRIVER CIRCUIT

To check the functionality of the proposed circuit, the circuit was simulated in PSIM 9.1 on a 9-W LED array with AC input voltage of 120 V_{rms} and switching frequency of 100 kHz. The driver circuit was designed for an output current with a peak value of 350 mA and a duty cycle of 45%. Driving LED with pulsed-current improves the stability of the luminous intensity of the LED while high DC current leads to saturating luminous level [12].

Each LED in the array has a voltage drop of 10.2 V. So, ten LEDs are connected in series to give an output power of 8.06 W. With the designed output power = 8.06 W and assuming an efficiency of at least 86%, the average input power is calculated to be 9.48 W.

As input voltage is 120 V_{rms}, peak input voltage V_p is 170 V using $V_p = 1.414 * V_{rms}$. For optimized input current shape, we choose a ratio of V_p/V_{dc} as 0.7. A ratio of V_p/V_{dc} = 0.7 is chosen to give V_{dc} = 245 V. V_{dc} must be greater than V_p and β has a strong impact on the input power factor ($\beta = V_p / V_{dc}$). Power factor drops significantly as V_{dc} becomes very close to V_p.

As V_{dc} increases, β drops and power factor increases significantly. However, further decreasing β actually decreases the power factor slightly. As β decreases, shape of the input current becomes more like a square waveform and input power factor drops. As a result, the lowest power factor that can be achieved, when the input current becomes a pure square waveform is 0.9.

With V_{dc} = 243 V and P_{i,avg} = 9.48 W and a 10% ripple in V_{dc}, the minimum value of C_d is 4.7 μF. As total LED voltage = 102 V, increasing turns ratio n lowers switch voltage stress V_{ds}. Turns ratio is chosen as n = 1.5 and inductance L_m is calculated to be 0.76 mH. An output filter capacitor (C_o) of 5.6 nF is added across the LED array to reduce the high frequency output voltage ripple.

IV. SIMULATION MODEL AND RESULTS

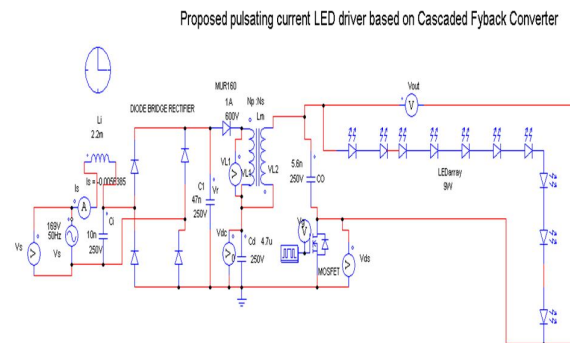

Fig. 7. PSIM Simulation Model of Proposed pulsating current LED driver

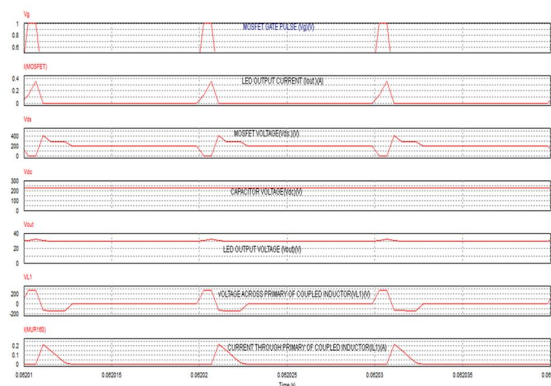

Fig. 8. PSIM Simulation Waveforms of Proposed pulsating current LED driver

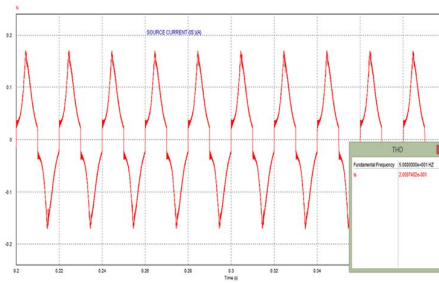

Fig. 9. Total Harmonic Distortion of input current using THD tool in PSIM Simulation

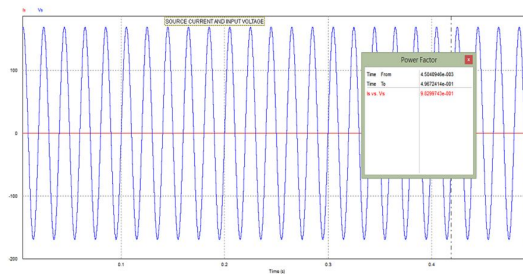

Fig. 10. Power Factor of input side using PF tool in PSIM Simulation

The simulation of proposed driver circuit was done using PSIM software as the power factor and total harmonic distortion can be directly obtained using the PF tool and THD tool. As the duty cycle decreases, the conduction period of the MOSFET switch reduces and the LED output voltage reduces leading to low level dimming and as the duty cycle increases, the conduction period of the MOSFET switch increases and the LED output voltage increases leading to higher luminous intensity.

The peak output current was obtained as 0.4A. The voltage across the primary winding was obtained as 50V and the LED output voltage as 85V for a duty ratio of 0.37. The achieved input power factor is 0.994 at the input side and the total harmonic distortion of the input current is 20.34%. The capacitor voltage is measured as 200V and the maximum voltage stress as 320V. The source current is almost sinusoidal with a value of 0.18A.

V. NOVELTY AND LIMITATIONS

The LED driver has longer lifetime and increased reliability due to absence of electrolytic capacitors. Harmonics of the input current is 20% which meets the IEC 61000-3-2 Class C standard leading to low Total Harmonic Distortion (THD).

The circuit has a high efficiency, lower cost due to fewer components and smaller size. It operates at a high input power factor of 0.99 and since the MOSFET switch is in output side, it experiences lower stress life leading to low power loss.

Moreover, the duty cycle can be varied leading to dimming function which reduces color changes in the LED with varying brightness levels.

Due to small leakage inductance on the secondary winding of L_m , small voltage spikes are observed on V_{ds} during the turn off instant. An RCD snubber circuit can be added to the proposed circuit to absorb the extra energy and reduce the voltage spike. Peak current is regulated with duty cycle control. But due to decrease in duty ratio to maintain the same peak current, the average output current decreases slightly for high line voltages.

VI. FUTURE SCOPE AND APPLICATIONS

As a future work, we plan to develop hardware model of a novel remote controlled long life LED driver lighting system with ON, OFF and dimming controls and measure the power factor and THD using a

flukemeter and the luminous intensity using Luxmeter. Dimmers are devices used to lower the brightness of a light. By changing the voltage waveform applied to the lamp, it is possible to lower the intensity of the light output. The PWM method of dimming is the actual start and restart of the LED current for short periods of time. The frequency (200Hz or faster) of this start-restart cycle is faster than the human eye that prevents flickering effect, about 200 Hz or faster is usually acceptable. The escalating brightness of retrofit LED lamps has made dimming more and more relevant and reduced efficacy in Lumens per Watt arises as the operating current exceeds the linear range. Operation above the linear range results in output power converted to heat from the LED. This wasted heat burdens the LED driver and increases the complexity of the thermal design. To achieve dimming, we adjust one of the control parameters (i.e., duty cycle, switching frequency, and so on) in the driver circuit. When the duty cycle (d) is decreased to provide low-level dimming, the capacitor voltage (V_{dc}) will be increased. The novel remote controlled LED driver can be used in industrial, commercial and domestic lighting applications.

VII. CONCLUSION

A novel long life single switch LED driver was proposed to reduce the low-frequency ripple on the LED current without any electrolytic capacitors or complicated control methods. The DCM operation of coupled inductor provides PFC and high frequency pulsating current to drive the LED. The detailed descriptions of the proposed circuit and circuit operating principles was studied. Simulation model in PSIM was realised to support the feasibility of the proposed circuit through a 9 W, 120 V_{rms} model. We are in the process of developing hardware model of a novel remote controlled long life LED driver lighting system with ON, OFF and dimming controls.

ACKNOWLEDGMENT

We would like to thank our college Rajagiri school of Engineering and Technology for providing academic and technical support. We also thank all teachers of the Department of Electrical Engineering for providing valuable guidance.

REFERENCES

- [1] International Standard, International Electrotechnical Commission (IEC), 6100032 Class C. 1 Ed, Mar. 1995.
- [2] ENERGY STAR Qualifying Criteria for Solid State Lighting (SSL) Luminaires, Version 1.3, U.S. Environmental Protection Agency and U.S. Dept. Energy, 2010.
- [3] S. Li, S.-C. Tan, S. Y. R. Hui, and C. K. Tse, "A review and classification of LED Ballasts," in Proc. IEEE Energy Convers. Congr. Expo., 2013, pp. 3102–3109.
- [4] P. Athalye, M. Harris, and G. Negley, "A two-stage LED driver for high performance high-voltage LED fixtures," in Proc. IEEE Appl. Power Electron. Conf. Expo., 2012, pp. 2385–2391.
- [5] A. Wilkins, J. Veitch, and B. Lehman, "LED lighting flicker and potential health concerns: IEEE standard PAR1789 update," in Proc. IEEE Energy Convers. Congr. Expo., 2010, pp. 171–178.
- [6] K. Zhao, P. Ciufu and S. Perera, "Lifetime analysis of aluminum electrolytic capacitor subject to voltage fluctuations", in Proc. 14th Int. Conf. Harmonics Quality Power, pp. 15, Sept. 2010.
- [7] S. Wang, X. Ruan, K. Yao, S.-C. Tan, Y. Yang, and Z. Ye, "A flicker free electrolytic capacitor-less AC-DC LED driver," IEEE Trans. Power Electron., vol. 27, no. 11, pp. 4540–4548, Nov. 2012.
- [8] W. Chen and S. Y. R. Hui, "Elimination of an electrolytic capacitor in AC/DC light-emitting diode (LED) driver with high input power factor and constant output current," IEEE Trans. Power Electron., vol. 27, no. 3, pp. 1598–1607, Mar. 2012.
- [9] P. S. Almeida, G. M. Soares, and H. A. C. Braga, "Off-line flyback LED driver with PWM dimming and power factor correction employing a single switch," in Proc. IEEE/IAS Int. Conf. Ind. Appl., 2012, pp. 1–7.
- [10] J. C. W. Lam and P. K. Jain, "Isolated AC/DC Offline High Power Factor Single-Switch LED Drivers Without Electrolytic Capacitors", in IEEE Journal of Emerging and Selected Topics in Power Electronics, vol. 3, no. 3, pp. 679-690, Sept. 2015.
- [11] J. C. W. Lam and P. K. Jain, "A High Power Factor, Electrolytic Capacitor-Less AC-Input LED Driver Topology With High Frequency Pulsating Output Current", in IEEE Transactions on Power Electronics, vol. 30, no. 2, pp. 943-955, Feb. 2015.
- [12] S. Buso, G. Spiazzi, M. Meneghini, and G. Meneghesso, "Performance degradation of high-brightness Light Emitting diodes under DC and pulsed bias," IEEE Trans. Device Mater. Rel., vol. 8, no. 2, pp. 312–322, Jun. 2008.